

OPERATION AND MAINTENANCE
MANUAL
BATTERY-POWERED TORQUE WRENCHES



IMPORTANT SAFETY INFORMATION ENCLOSED.
READ THIS MANUAL BEFORE OPERATING TOOL.
IT IS THE RESPONSIBILITY OF THE EMPLOYER TO
PLACE THE INFORMATION IN THIS MANUAL INTO
THE HANDS OF THE OPERATOR. FAILURE TO
OBSERVE THE FOLLOWING WARNINGS COULD
RESULT IN INJURY.

MODEL: **TBEW**

1.0 Receipt Notice

1.1 Receipt should check the appearance of the machine and all components for damage in transit. If you find the machine or component damage, notify the carrier immediately. Damage in transit is not covered under warranty. All repairs and replacement costs resulting therefrom shall be borne by the carrier.

1.2 Battery torque wrench standard configuration includes the following components: wrench body, reaction arm, manual, two 5.0AH battery and one charger, if in doubt, please contact the supplier.

2.0 Functional Description

Product Overview: **TBEW** series battery torque wrench is a hand-held rotary power tool, with a reaction arm, can be precisely set the torque for the completion of a nut or bolt tightening / loosening job, with a torque compensation function which can help clients calibrated when they doubt the output accuracy: drive part with high-efficiency brushless DC motor, high-speed smart chip control, LED display, mechanical parts using planetary gear mechanism.

Motor main technical parameters: :

- Power supply -----18V
- Power free speed -----13000rpm
- Battery capacity -----5Ah (Standard)、9Ah (Optional)

3.0 Notice before operate the tool

Only the approved lithium battery provided by this wrench can be used

Do not remove the mechanical and electrical parts of the wrench without permission



Danger

This machine is a power tool with a reaction arm, a huge machine-generated torque absorbed by the reaction arm, so have to find enough strength to anchor reaction arm during operation. For security reasons, when the machine is working, any part of the body have to be away from work ranges of reaction arm, otherwise, will inevitably cause great harm to persons.

4.0 Battery torque wrench component

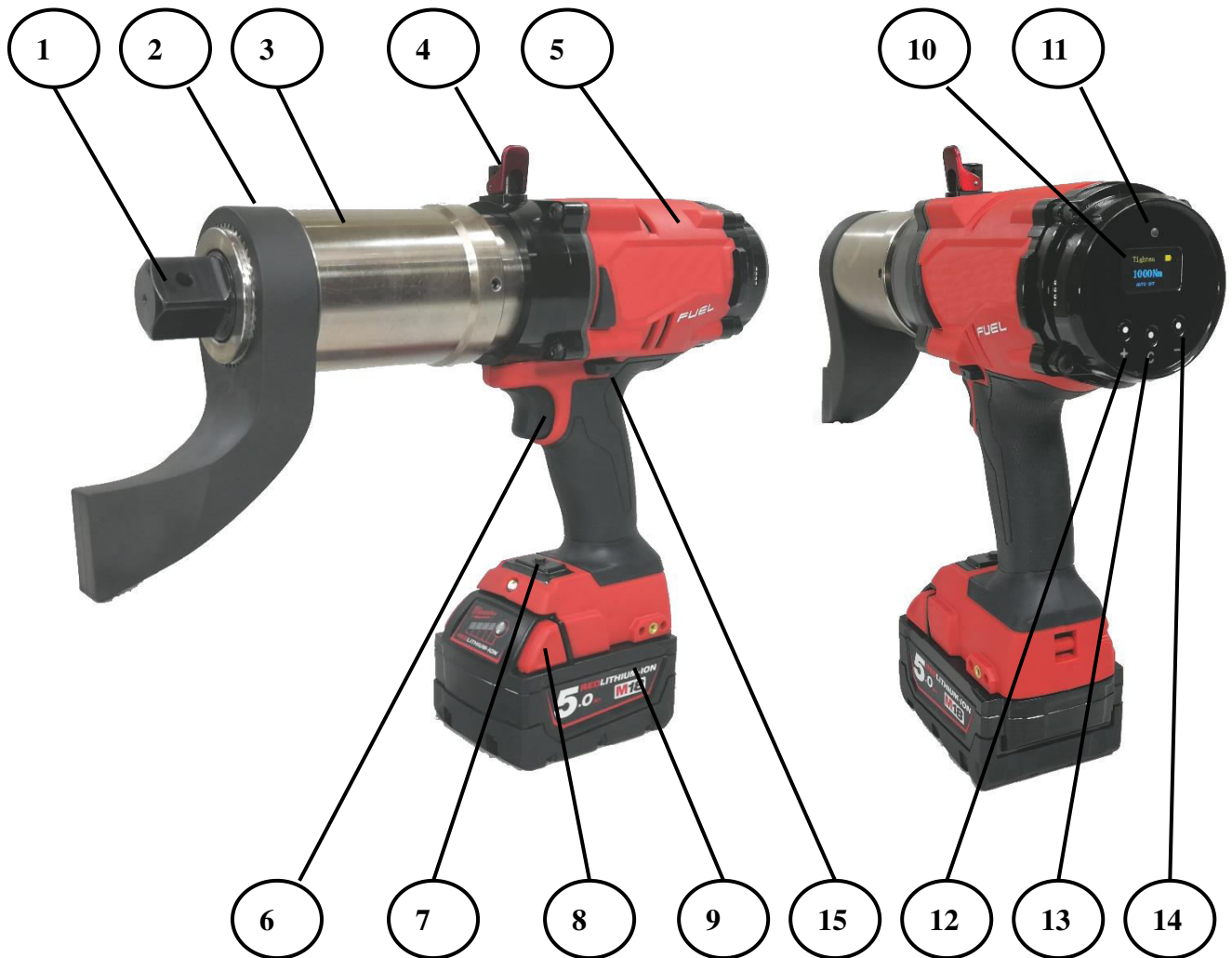

1-SQUARE DRIVE 2-REACTION ARM 3-GEAR BOX 4-LOCKING BUTTON 5-MOTOR 6-TRIGGER TO START 7-SWITCH POWER ON/OFF 8-REMOVE BATTERY BUTTON 9-BATTERY

10-LED SCREEN 11-WORK INDICATING LAMP 12-+TORQUE INCREASE 13-CONFIRM BUTTON 14-

-REDUCE TORQUE 15-LOOSEN OR TIGHTEN BUTTON

PRESS NO.7 SWITCH ON/OFF, NO.10 SHOWS SYSTEM START, PRESS NO.7 AGAIN SYSTEM STOP AND POWER OFF

IMPORTANT WHEN USING THE TOOL (TIGHTENING OR LOOSENING)

LOCKING BUTTON:

ADJUST THE MOTOR POSITION (UNLOCK HELPS USER EASIER TO ADJUST POSITION OF HANDLE)

UNLOCK (MOTOR FREE ROTATING SEPERATE WITH GEAR BOX)



LOCK (PULL THE BUTOON UP)

BEFORE PRESS THE NO.6 TRIGGER, FIND A STRONG ENOUGH REACTION POINT FOR THE NO.2 REACTION ARM AND PULL THE BUTTON UP TO LOCK THE MOTOR.

THE LOCKING BUTTON SHOULD ALWAYS LOCK WHEN THE REACTION ARM CLOSE TO THE REACTION POINT. THE LOCKING COMPONENT MAKE THE WRENCH NON-IMPACT FORCE



LED SCREEN INFO

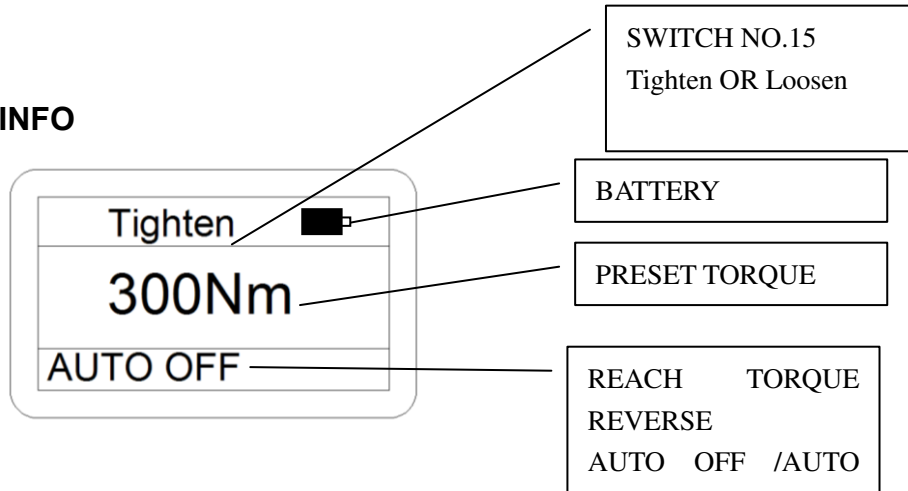

AUTO REVERSE FUNCTION: PRESS “+” BUTTON AND HOLD FOR 1-2 SECOND, IT WILL CHANGE TO AUTO ON, WHEN TIGETHNING THE NUT, WHEN REACH TORQUE KEEP HOLD THE NO.6 TRIGGER WRENCH WILL AUTO REVERSE FOR 15 DEGREE (THE AUTO REVERSE WORK ONLY WHEN THE USER KEEP HOLDING THE NO.6 TRIGGER).

NOTICE: AUTO OFF MEANS, THE USER HAVE TO REVERSE THE WRENCH BY MANUAL. SWITCH NO.15 AND REVERSE THE REACTION ARM. THEN TAKE THE WRENCH TO OTHER APPLICATION.

JHBEW----S series two operating models for user to select:

First operating mode-----Digital torque selection

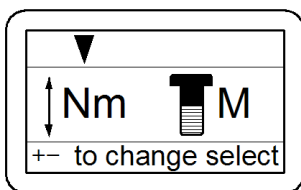

Press the “C” button, enter torque select, press “+”“-” button and move the ▼ on top of the “Nm”

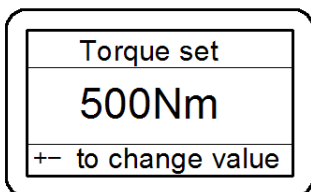

Press “C” button, enter torque select, press “+”“-” button to change the torque value



During this process, press the No.6 trigger wrench will not work

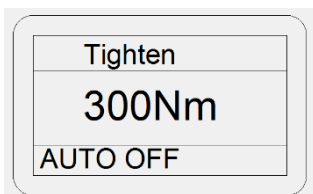

Press “C” button, torque set finish, press the No.6 trigger, wrench start work

Second operating model-----Bolt grade selection

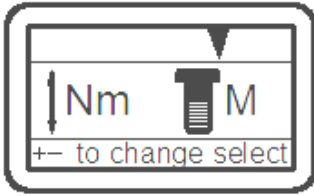

Press “C” button, enter bolt size select, Press “+” “-” button and move ▼ on top of the “M”

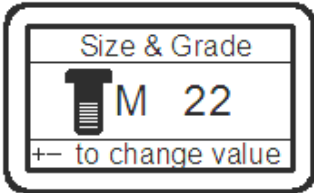

Press “C” button, enter bolt size select, Press “+” “-” button to change bolt grade (DIN Standard bolt);

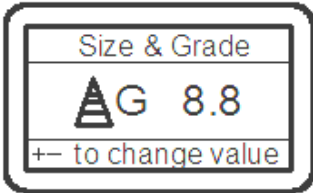

Press “C” button, enter bolt grade select, Press “+” “-” button to select the bolt grade;



During this process, press the No.6 trigger wrench will not work

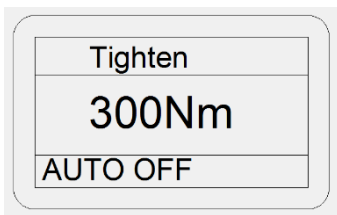

Press“C”button,it will show the torque requirements (According to Din Standard), press No.6 trigger wrench will start work,

Torque compensation function: Press “+” “-” button together for a second and enter calibration model

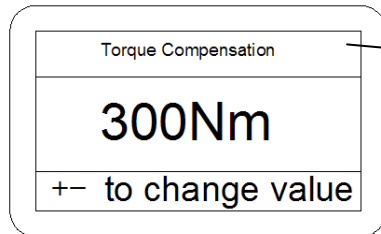

During this process press+-button to change the values that user want adjust

Torque compensation example: When the user set 2000Nm, but calibration result shows the torque is 2300Nm. Calibration equipment shows output is over torque 300Nm. At this moment, user press +- button together and hold for seconds. Then user enter torque compensation model, user have to press “-” button and make it -300Nm. After this, calibrate wrench again. Keep changing the torque until the torque meets the users’ calibration equipment accuracy. If its less torque output, user have to press “+” button during the

torque compensation process.



Torque compensation function may need several times to adjust in order to reach the target calibration result

This torque output accuracy should be calibrated in every 6 month if it needs.

5.0 Operation process

1. Press the No.7 button switch on the wrench
2. Enter the target torque
3. Let the reaction arm close or reach the reaction point, pull the No.4 button up and lock the wrench.
4. Keep press the No.7 trigger, wrench start work and do not leave the trigger until wrench stop and indicate lamp off (During auto on model, do not stop until wrench reaction arm reverse).

6.0 Product Maintenance and precautions

- 7.1 machinery and motor cooling vent must be kept clean all the time, so that it can improve the quality and safety at work .
- 7.2 Maintenance the gearbox and transmission part regularly, replace new grease recommended penetration level is 265-295 with a viscosity grade 2 grease
- 7.3 Regularly check the machine is working properly , and make sure if there is broken or damaged parts. Be sure to replace or repair faulty parts before using machine.
- 7.4 Can only be entrusted to professional power tool maintenance, repair, only original spare parts for maintenance
- 7.5 When replacing parts or not using the machine, be sure to pull the plug socket, it will avoid accidentally starting the power tool .

7.0 General warning of operating

- 8.1 Wear personal protective equipment. For example, earmuffs, because working noise may damage your hearing. Better to wear protective glasses, work gloves , non-slip work shoes , helmets, work aprons , etc. , can reduce the chance of injury work .
- 8.2 The power cord must stay away from the operating area, when operating the machine wire must be placed in the rear fuselage.
- 8.3 Power cord should be away from heat , oil, sharp edges or rotating parts. If the power cord is damaged or twisted together, will increase the risk of electric shock .
- 8.4 correctly handle the wires. You can not use wire to handle tools, power tools or hanging wire to pull way to pull the plug .
- 8.5 Before plug it in , lifting or carrying the machine , be sure to check if the machine is turned off , if you tie power tools, fingers touching the switch , or when connecting the power off switch is still set at start of position , may cause very serious accidents.

8.6 Avoid erroneous holding machine posture. When operating the machine to make sure footing and to keep in balance. Correct operating posture can help you in emergency situations in a timely manner to control power tools.

8.7 wear suitable clothes. Not too loose clothes to wear at work , it can not wear jewelry. Keep your hair , clothing and gloves touching the rotating parts of the machine . Loose clothing , long hair or jewelry easily be caught in moving machine.

8.8 Avoid physical contact with metal objects , such as pipes, radiators , etc. If your body is grounded , and very vulnerable to shock .

8.9 Do not use the switch malfunctioning machine . If you can not properly control the start and stop switch , prone to accidents when operating the machine. Machine repair the fault as soon as possible .

8.10 Engrossed affairs work necessary , not only to keep a clear head but also to rational operation of the machine. Tired , drinking or taking drugs , stimulants, the drugs , do not use a power tool . When using the machine as long as a little distraction might occur serious unintended consequences .

8.11 Keep children and bystanders away while operating the machine. Work distracted because of the interference of a third party may cause accidents.

8.12 When not using the tool , the machine must be stored in the toolbox. Do not let someone who is unfamiliar with machine operation and did not read the manual use the machine. Let inexperienced person to operate is accident-prone.

8.13 The machine must stay away from rain or moisture. If you let water seep power tools will increase the risk of electric shock .

8.14The machine can not operate in a dangerous explosive environment. Potentially explosive environment is full of flammable liquids, gases or dust in the workplace. When operating the machine will produce sparks, sparks easily ignite dust or flammable vapors.

8.15The workplace must be clean and the sufficient light. Messy or dark workplace easily lead to accidents.

8.16 Do not allow the machine to withstand heavy loads. Choose the suitable model,it's more safe to operate.

8.0 Warranty

9.1 The delivery date from the machine , the user warranty service on this equipment.

9.2 Warranty service will need product serial number.

9.3 The following conditions are not covered under warranty services:

- 1 Out of warranty period ;
- 2 The user can not provide " Warranty Card" and invoices or other proof materials ;
- 3 The equipment does not work properly due to force majeure ;
- 4 Consumable parts and wearing parts , such as : Brush ;
- 5 The damage caused by human factors